



Meaning Map



Objective

The student will identify attributes of words.



Materials

- ▶ Chart paper
Write target vocabulary words or write word(s) on Meaning Map when it is copied for students.
- ▶ Meaning Map
- ▶ Resources (e.g., dictionary, encyclopedia, books, textbooks).
- ▶ Pencils



Activity

Students write words related to a topic and record the words on a semantic map.

1. Place resources at the center. Provide each student with a Meaning Map.
2. Student reads the target word.
3. Reads the categories or questions in each box on the Meaning Map and writes a one word answer or sentence for each area (i.e., What is it?, Examples, Description).
4. Teacher evaluation

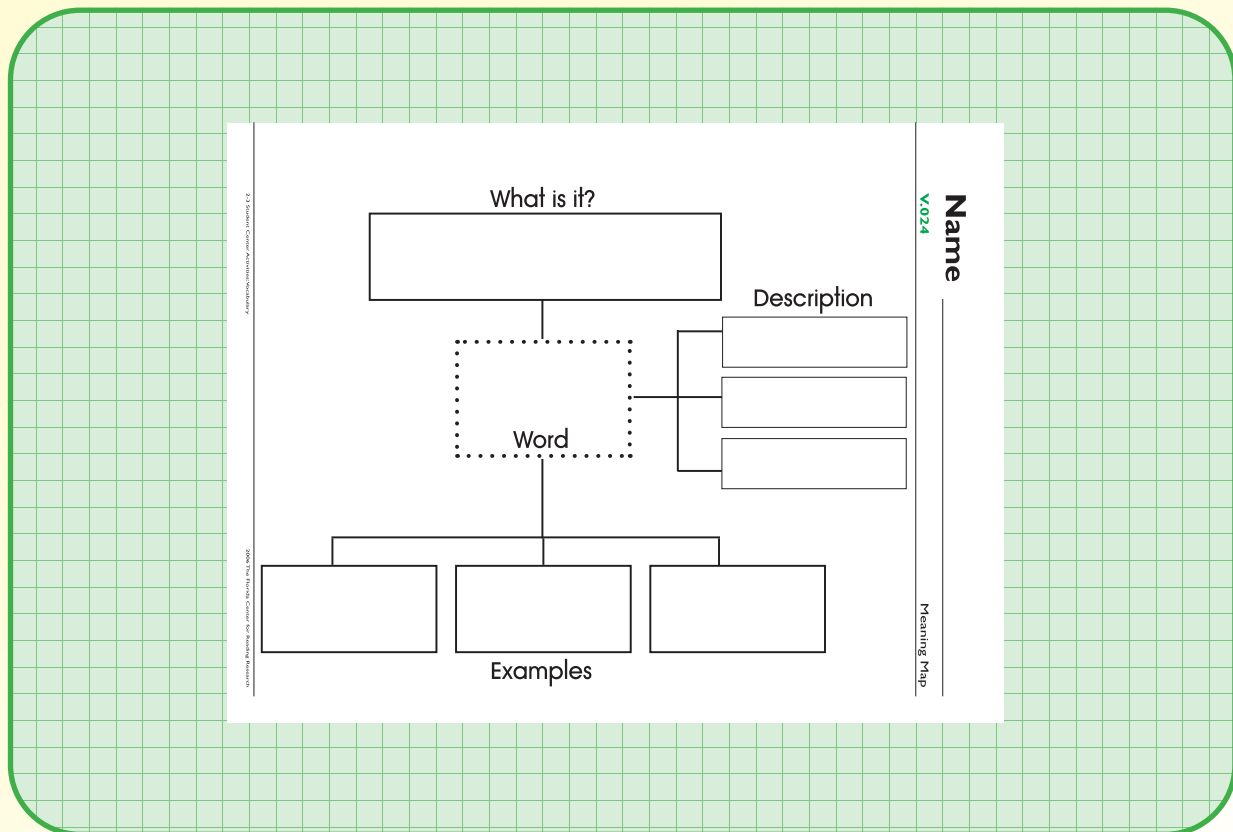

Extensions and Adaptations

- ▶ Use other meaning maps. Write the target topic or keyword in the center of the map. Write categories or questions in the various circles or boxes.

Name _____

V. 024

Meaning Map

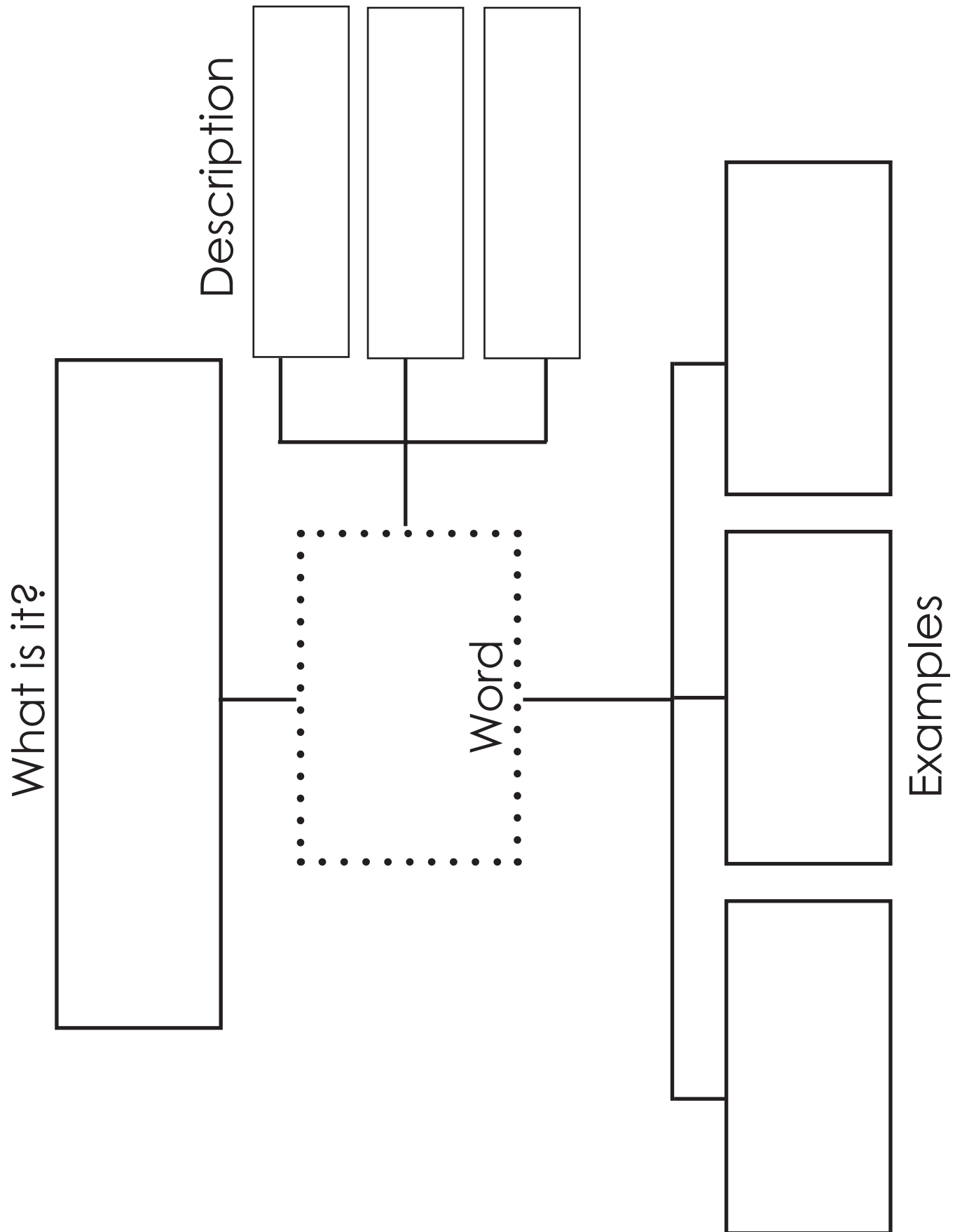

Name _____

Meaning Map

V. 024

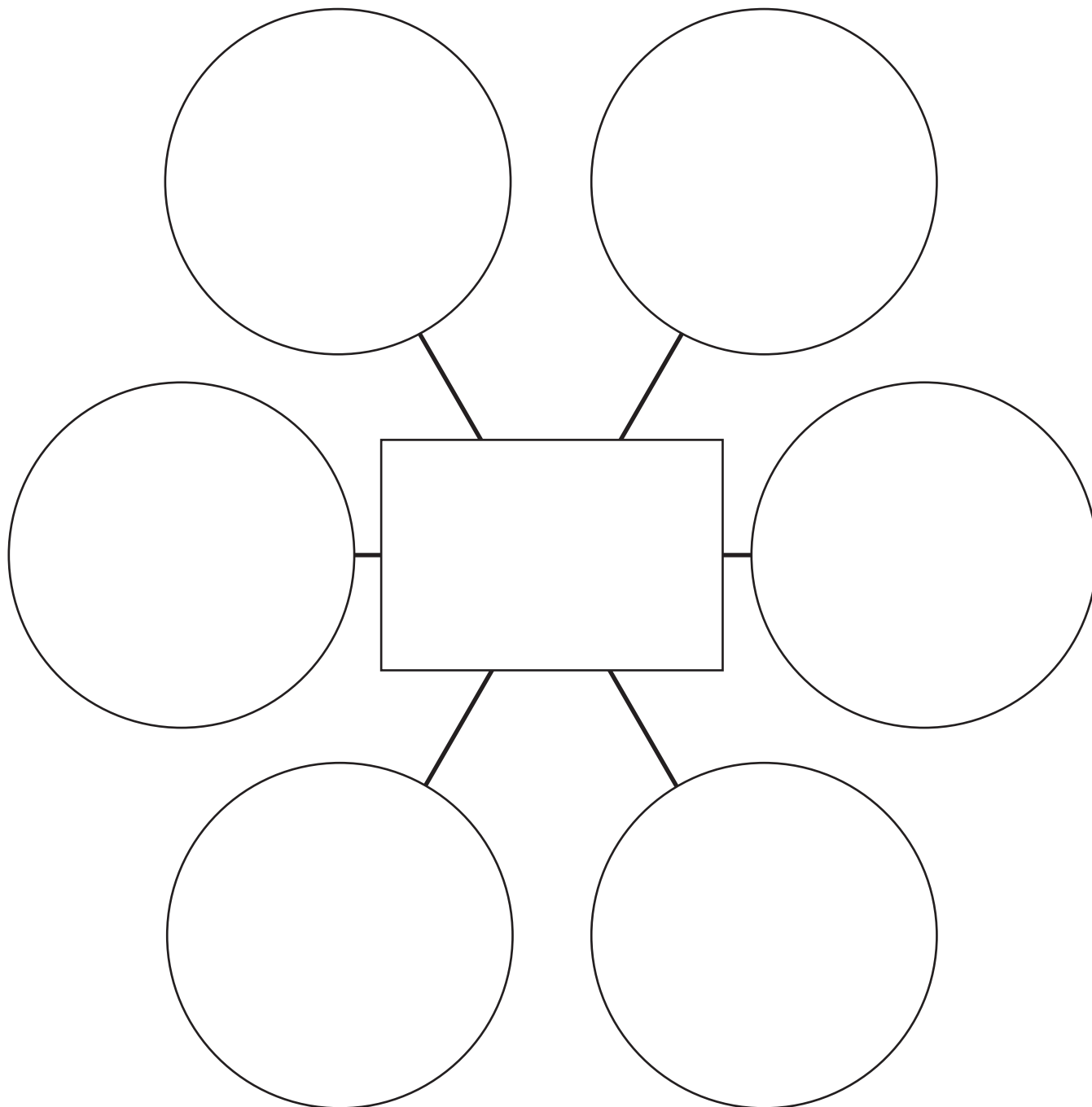

Name _____

V. 024

Meaning Map

